

HF High Power Reader



Model: RR9001TUSB-M12

Size: 116mmx104mmx27mm

Weight: 200g

GENERAL DESCRIPTION

RoyalRay HF high power tag readers RR9001TUSB-M12 is designed upon fully self-intellectual property. Based on proprietary efficient anti-collision algorithm, the series features excellent tag read/write operation performance with high identification rate. The series can be widely applied in many RFID application systems such as Logistics, Personnel Identification, Conference Attendance, Access Control, Anti-counterfeit, Jewelry Management, Self-service of Laundry and Industrial Process Control.

FEATURES

- Self-intellectual property;
- Support ISO/IEC15693, ISO18000-3 protocol tags;
- RF output power over 1W;
- Advanced anti-collision algorithm, high identification rate, typical tag process speed is over 80 tags/s;
- Support standard 50ohm RFID antenna with effective distance up to 70cm*;
- Antenna open/short circuit tolerant;
- Support Transparent Command operation^①;
- Support addressable multiple antenna ports;
- Support DPPM/WPPM tag-parsing mode^②;
- Support reader network;
- Low power dissipation design;
- Provide DLL and Demonstration Software Source code to facilitate further development.

^①Transparent Command Operation: It is an advanced feature designed to support tag's future functions and different chip vendors' customized tag functions.

^②DPPM/WPPM Tag-parsing Mode: DPPM tag-parsing mode means depth-first parsing pattern and WPPM means breadth-first parsing pattern. They are different methods of decoding multiple tags.

INTERFACE DESCRIPTION

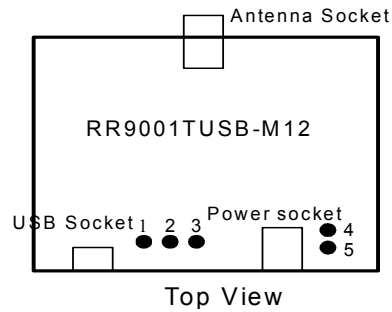

No.	SYMBOL	COMMENT
1	TXD	RS232 serial data output
2	RXD	RS232 serial data input
3	GND	Ground
4	VCC	+12V
5	GND	Ground

CHARACTERISTICS

- Absolute Maximum Rating

ITEM	SYMBOL	VALUE	UNIT
Power Supply	VCC	16	V
G_IN1, G_OUT1, G_OUT2 I/O Voltage	V _{IO}	7	V
Operating Temp.	T _{OPR}	-20 ~ +65	°C
Storage Temp.	T _{STR}	-25 ~ +80	°C

- Electrical and Mechanical Specification

Under T_A=25°C, VCC=+12V unless specified

ITEM	SYMBOL	MIN	TYP	MAX	UNIT
Power Supply	VCC	11.5	12	15	V
Current Dissipation	I _C		350	450	mA
Frequency	F _{REQ}		13.56		MHz
Effective Distance *	DIS	0	700	850	mm

*Effective distance depends on RF output power, antenna, tag and working environment.

Remark:

1. Specifications are subject to change, please pay attention to our latest one.

2. Shenzhen RoyalRay Science and Technology Co., Ltd. reserves the right to the final interpretation of the above terms.

Page 3, Total3

Shenzhen RoyalRay Science and Technology Co., Ltd.

www.rr-rfid.com

Add: Rm.116, Luohu Science & Technology Bldg., No.85 Taining Rd., Shenzhen, P.R.C.

Tel: +86 755 25531562 25636705

Fax: +86 755 25531562

E-Mail: market@rr-rfid.com